

**Rotary actuator for butterfly valves**

- Torque motor 35 Nm
- Nominal voltage AC 230 V
- Control Open/close, 3-point
- with 2 integrated auxiliary switches

**Technical data**

<b>Electrical data</b>	Nominal voltage	AC 230 V
	Nominal voltage frequency	50/60 Hz
	Nominal voltage range	AC 198...253 V
	Power consumption in operation	68 W
	Power consumption in operation note	incl. heating
	Power consumption for wire sizing	68 VA
	Current consumption	0.4 A
	Auxiliary switch	2 x SPDT, 1 x 3° / 1 x 87°
	Switching capacity auxiliary switch	1 mA...3 A (0.5 A inductive), DC 5 V...AC 250 V
	Connection supply / control	Terminals 1.5 mm <sup>2</sup> for wire 0.5...1.5 mm <sup>2</sup>
Parallel operation	No	
<b>Functional data</b>	Torque motor	35 Nm
	Manual override	temporary with open-end wrench
	Angle of rotation	90°
	Angle of rotation note	Internal limit switch
	Running time motor	14 s / 90°
	Duty cycle value	30% (= active time 14 s / operating time 47 s)
	Sound power level, motor	70 dB(A)
	Position indication	Mechanically (integrated)
	<b>Safety</b>	Protection class IEC/EN
Protection class auxiliary switch IEC/EN		I protective earth (PE)
Degree of protection IEC/EN		IP67
EMC		CE according to 2014/30/EU
Low voltage directive		CE according to 2014/35/EU
Mode of operation		Type 1
Control pollution degree		4
Ambient temperature		-20...65 °C
Storage temperature		-30...80 °C
Ambient humidity		Max. 95% r.H., non-condensing
Servicing	maintenance-free	
<b>Mechanical data</b>	Connection flange	F05
<b>Weight</b>	Weight	2.1 kg
<b>Materials</b>	Housing material	Die cast aluminium

## Safety notes



- This device has been designed for use in stationary heating, ventilation and air-conditioning systems and must not be used outside the specified field of application, especially in aircraft or in any other airborne means of transport.
- Outdoor application: only possible in case that no (sea) water, snow, ice, insolation or aggressive gases interfere directly with the actuator and that is ensured that the ambient conditions remain at any time within the thresholds according to the data sheet.
- Caution: Power supply voltage!
- Only authorised specialists may carry out installation. All applicable legal or institutional installation regulations must be complied during installation.
- The device does not contain any parts that can be replaced or repaired by the user.
- The device contains electrical and electronic components and must not be disposed of as household refuse. All locally valid regulations and requirements must be observed.

## Product features

<b>Simple direct mounting</b>	Simple direct mounting on the butterfly valve. The mounting orientation in relation to the butterfly valve can be selected in 90° (angle) increments.
<b>Manual override</b>	Manual operation with open-end wrench (rotating the open-end wrench in clockwise direction opens the butterfly valve).
<b>Internal heating</b>	An internal heater prevents condensation buildup.
<b>High functional reliability</b>	The internal limit switches interrupt the voltage supply to the motor. In addition, a motor thermostat provides overload protection and interrupts the voltage supply if the actuator is used outside of the specified temperatures.
<b>Combination valve/actuator</b>	Refer to the valve documentation for suitable valves, their permitted fluid temperatures and closing pressures.
<b>Signalling</b>	The integrated auxiliary switches are equipped with a gold/silver coating that permits integration both in circuits with low currents (mA range) and in ones with larger-sized currents (A range) in accordance with the specifications in the data sheet. It should be noted with this application however that the contacts can no longer be used in the milliampere range after larger currents have been applied to them, even if this has taken place only once.

## Electrical installation



**Notes** • Caution: Power supply voltage!

## Wiring diagrams

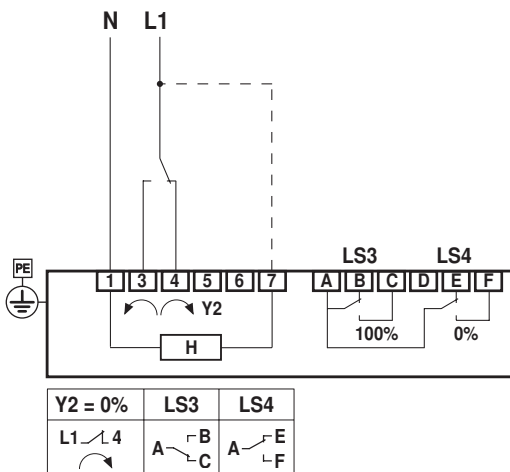

H: Internal heating (no need to connect internal heating for indoor applications with constant temperature conditions)  
 LS3: Auxiliary switch 100% (butterfly valve open)  
 LS4: Auxiliary switch 0% (butterfly valve closed)

## Settings



### Notes

- Limit switches TC1/TC2 and angle of rotation limitation are provided with sealing varnish and may not be adjusted.

### Setting cam

The setting cams for limit and auxiliary switches can be accessed by removing the housing cover.

Optionally, auxiliary switches LS4 / LS3 can be connected for signalling.

Limit switches LS2 / LS1 interrupt the voltage to the motor and are controlled by setting cams TC..

The setting cams turn with the stem. The butterfly valve closes when the stem is turning clockwise (cw) and opens when the stem is turning counterclockwise (ccw).

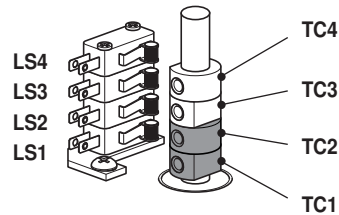

TC1/TC2 with sealing varnish: limit switches are secured against adjustment

### Settings of setting cams TC..

- TC4 for auxiliary switch position closed (factory setting 3°).
- TC3 for auxiliary switch position open (factory setting 87°).
- TC2 for limit switch closed (0°).
- TC1 for limit switch open (90°).

### Adjusting setting cams

- 1) Use a 2.5 mm Allen key to unscrew the corresponding setting cams TC..
- 2) Turn the setting cam using the Allen key
- 3) Set as shown in the illustration below
- 4) Use the Allen key to tighten the corresponding setting cams

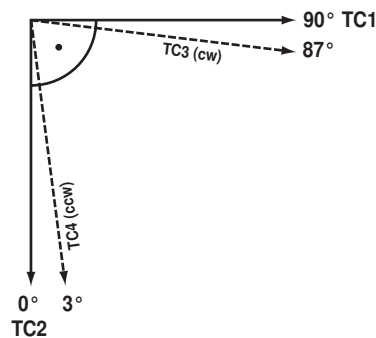

TC1: OPEN  
TC2: CLOSED  
TC3: Present position  
TC4: Desired position

## Dimensions [mm]

## Dimensional drawings

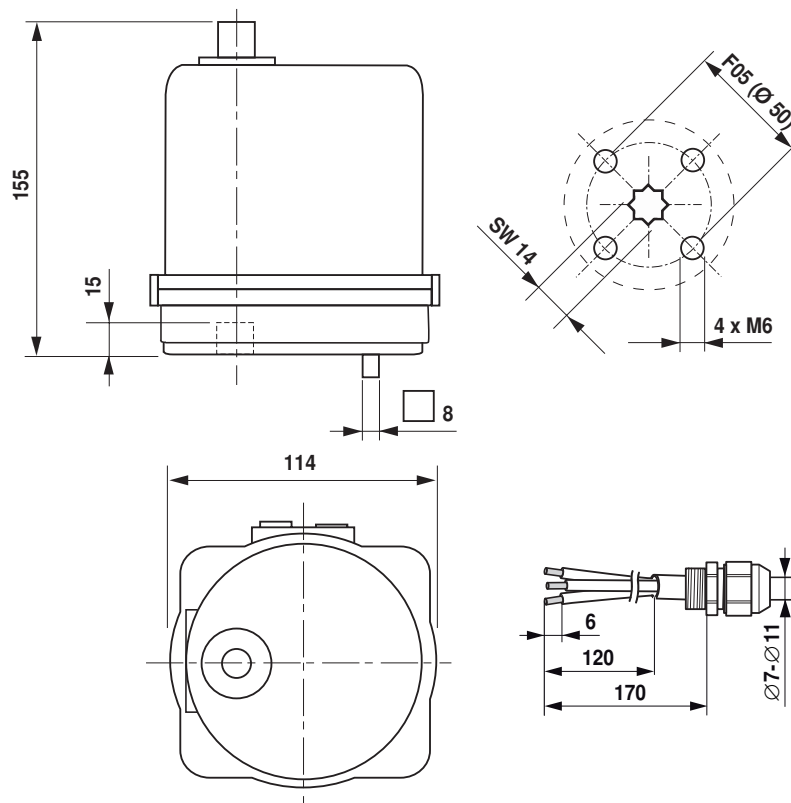

## Further documentation

- Data sheets for butterfly valves
- Installation instructions for actuators and/or butterfly valves
- Notes for project planning for butterfly valves