

Balancing Valves

V4 Kombi-F Series

FLANGED BALANCING AND SHUT-OFF VALVES

PRODUCT SPECIFICATION SHEET



CONTENTS

- Design.....1
- Materials.....1
- Application.....1
- Features.....1
- Specifications.....2
- Dimensions and ordering information.....2
- Flow diagrams V4 Kombi-F.....3 to 12
- Influence of coolants on flow values.....13
 - Correction factor f.....13

Application

The hydronic balance is a significant requirement for the efficient operation of a hydronic heating or cooling installation. In an unbalanced system under or over provision of hot water to individual radiators or circuits can occur. Apart from the correct selection of radiator valves, regulation of individual circuits is also necessary and in some cases, such as DIN 18 380, VOB part C, is required by national standards. This requirement is met with V4 Kombi shutoff and balancing valves. V4 Kombi have functions shut-off, pre-setting and measuring.

Features

- **Balancing through stroke limitation with digital pre-setting and visible pre-setting indicator**
- **Equipped with 2 pressure test cocks for differential pressure measurement**
- **Non rising spindle with EPDM and EPDM O-ring sealing**
- **Pre-setting isn't altered when handwheel is turned**
- **Regulation screw protected by protection cap**
- **PTFE seat sealing**
- **Valve cartridge and spindle made of cast steel**
- **Available in dimensions up to DN400**

Design

- Valve body with flanges drilled to DIN
- Valve insert with handwheel and pre-setting display
- Pressure test cocks

Materials

Part	Material	Standard
1. Body	Cast Iron	EN-JL1040
2. Bonnet	Cast Iron	EN-JL1040
3. Insert	Carbon Steel, chromium plated with PTFE seat ring	CLA ₁ Gr. B
4. Gasket	Graphite	304S15+
5. Stem	Stainless Steel	420S37
6. Handwheel	Ductile Iron	EN-JS1050

Specifications

Flange	BS4504 PN16 or ANSI B16.1 Class 125. Other flange types are available.
Operating temperature	-10 to 120 °C (14 to 248 °F)
Nominal pressure	16 Bar or 125 Psi
kvs-values	see table below and flow

Dimensions and ordering information

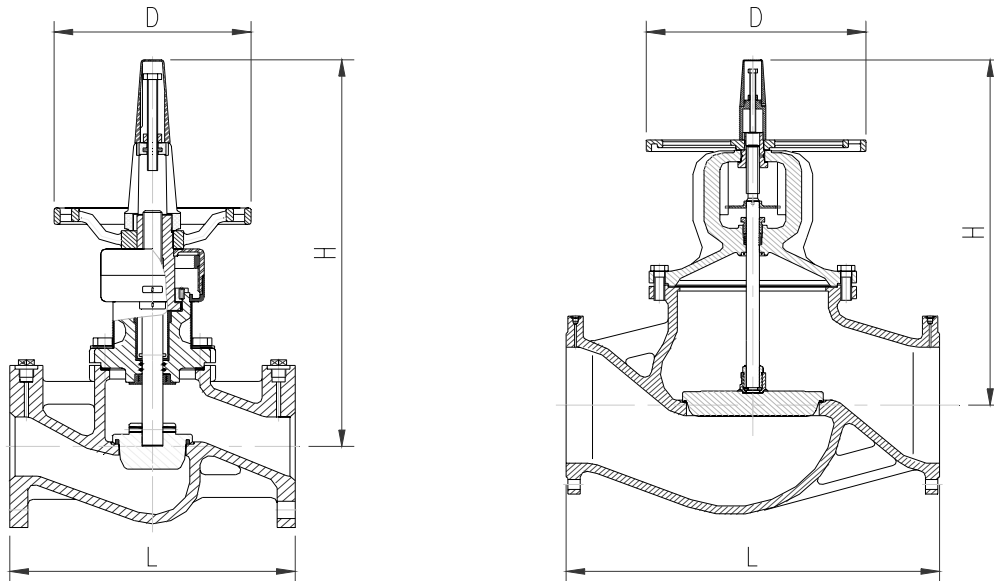

DN	(R)	kvs-value	L	H	Ø D	n x Ø d	OS-No.
65	2 1/2"	74,4	290	420	190	4 x 18	V4-BLC-GP16-G065
80	3"	111	310	443	190	8 x 18	V4-BLC-GP16-G080
100	4"	165	350	477	190	8 x 18	V4-BLC-GP16-G100
125	5"	242	400	511	305	8 x 18	V4-BLC-GP16-G125
150	6"	372	480	550	305	8 x 22	V4-BLC-GP16-G150
200	8"	704	600	665	305	8 x 22	V4-BLC-GP16-G200

DN	(R)	kvs-value	L	H	Ø D	n x Ø d	OS-No.
250	10"	945	730	829	515	12 x 22	V4-BLC-GP16-G250
300	12"	1.635	850	883	515	12 x 26	V4-BLC-GP16-G300

NOTE: All dimensions in mm unless otherwise stated

Flow diagram V4 Kombi-F, DN 65

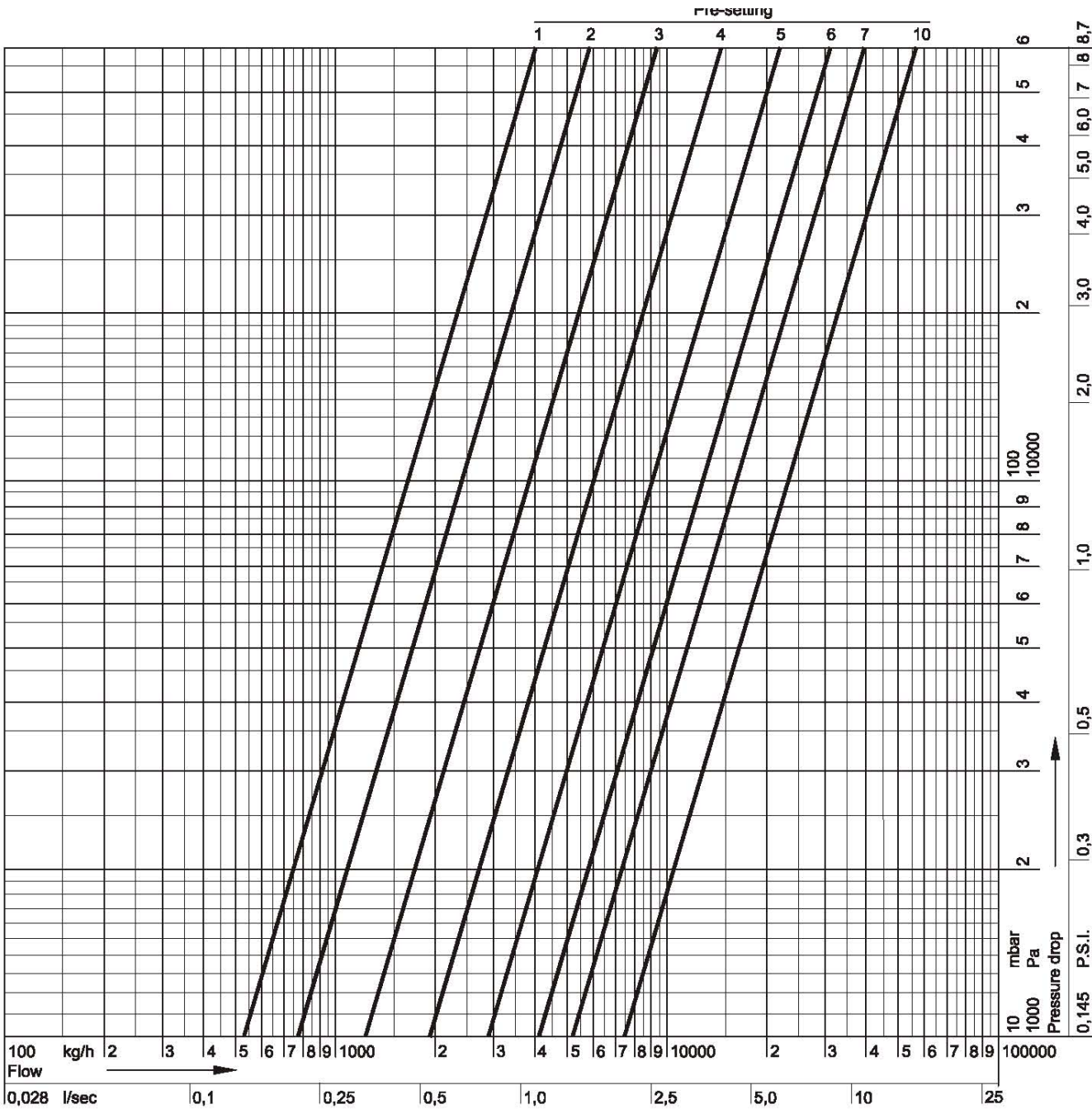

Pre-setting	0,5	1,0	1,5	2,0	2,5	3,0	3,5	4,0	4,5	5,0	5,5	6,0	6,5	7,0	8,0
kv-value	2,98	5,30	6,64	7,80	9,60	12,1	15,2	19,0	23,6	29,1	35,2	41,3	47,0	52,1	60,7

Pre-setting	9,0	10,0 = open
kv-value	67,9	kv _s = 74,4

Flow diagram V4 Kombi-F, DN 80

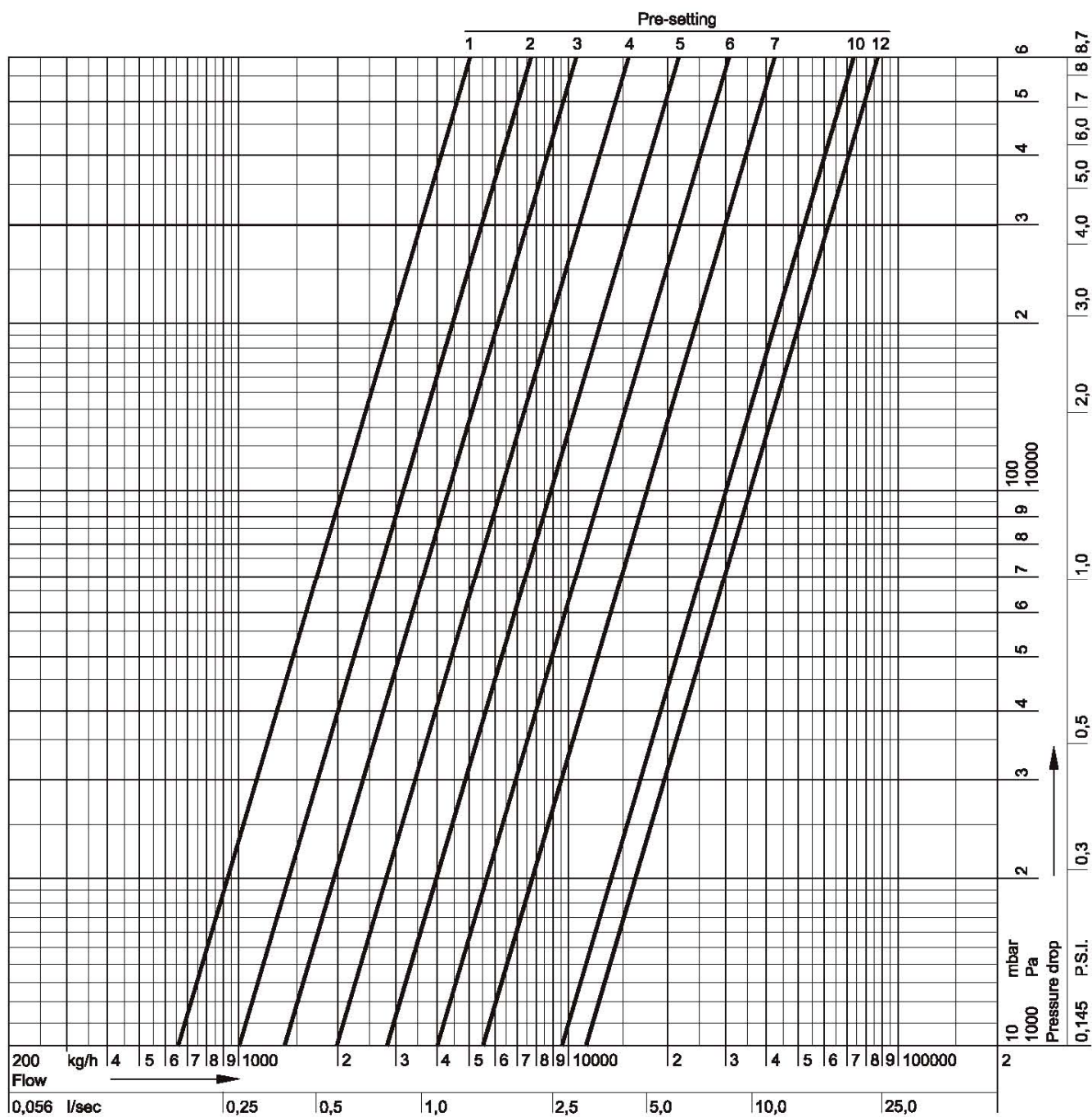

Pre-setting	0,5	1,0	1,5	2,0	2,5	3,0	3,5	4,0	4,5	5,0	6,0	7,0	8,0	9,0	10,0
kv-value	3,65	6,60	8,52	10,0	11,7	13,7	16,1	19,2	23,2	28,1	40,4	55,4	70,9	84,8	96,1

Pre-setting	11,0	12,0 = open
kv-value	104	k _{vs} = 111

Flow diagram V4 Kombi-F, DN 100

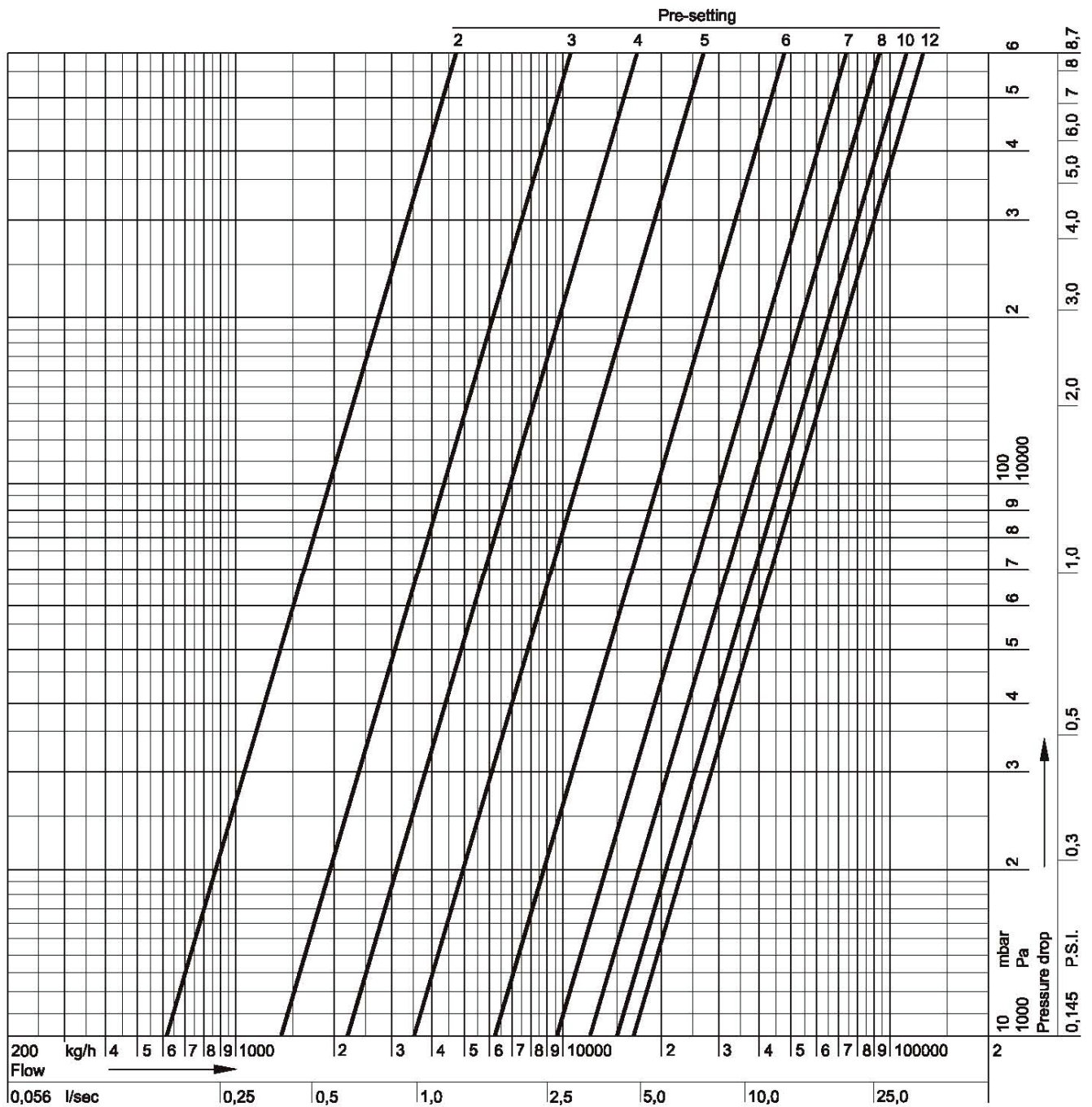

Pre-setting	1,5	2,0	2,5	3,0	3,5	4,0	4,5	5,0	5,5	6,0	6,5	7,0	7,5	8,0	9,0
kv-value	3,80	6,20	9,60	13,4	17,3	21,8	27,6	35,7	47,2	62,4	79,3	96,6	110	121	137

Pre-setting	10,0	11,0	12,0 = open
kv-value	148	157	kv _s = 165

Flow diagram V4 Kombi-F, DN 125

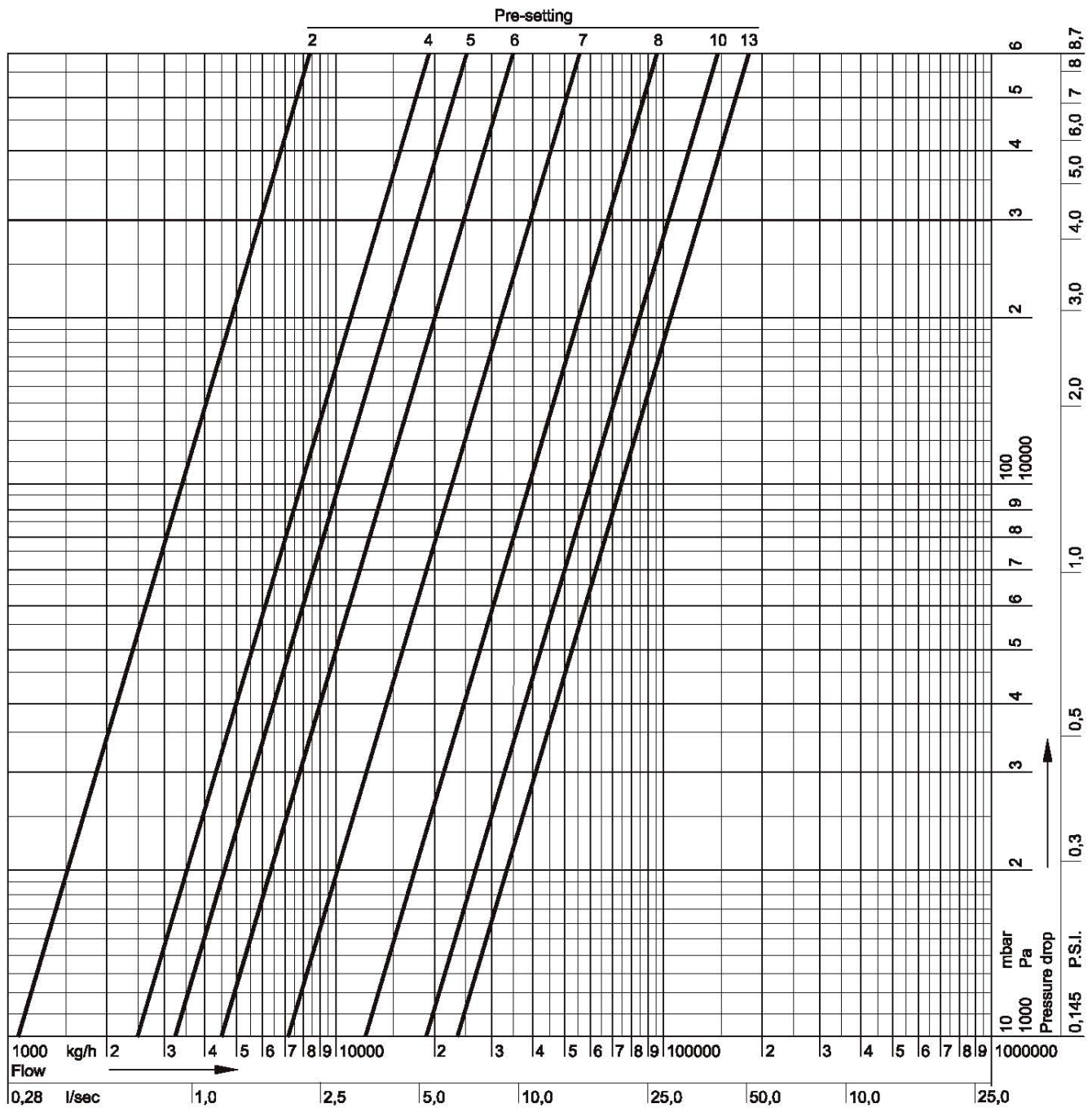

Pre-setting	1,5	2,0	2,5	3,0	3,5	4,0	4,5	5,0	5,5	6,0	6,5	7,0	7,5	8,0	9,0
k_v-value	8,30	11,3	14,4	17,7	21,1	24,6	28,2	32,3	37,4	44,9	56,1	72,5	93,2	120	162

Pre-setting	10,0	11,0	12,0	13,0 = open
k_v-value	192	211	225	k _{vs} = 236

Flow diagram V4 Kombi-F, DN 150

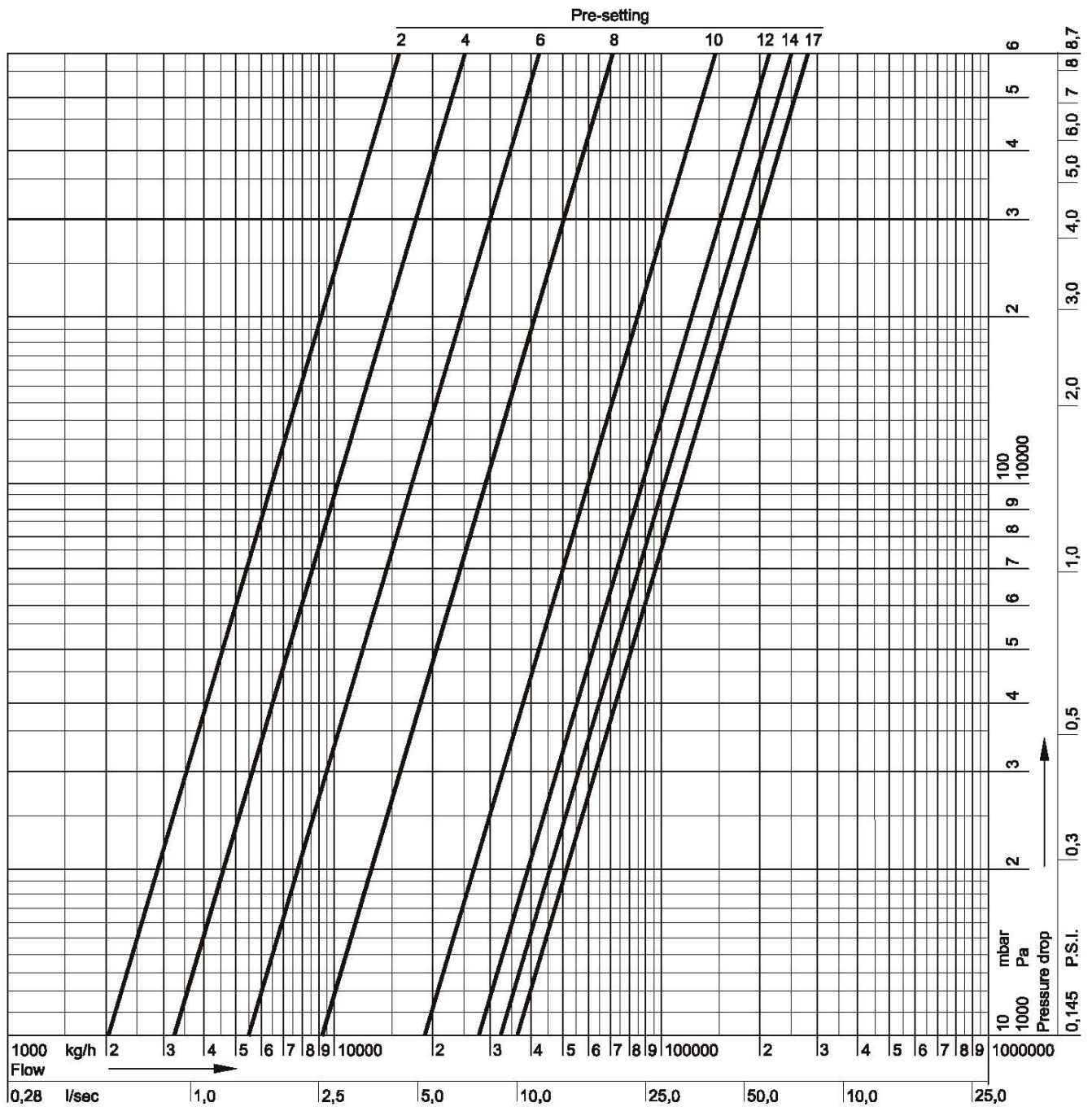

Pre-setting	1,5	2,0	2,5	3,0	3,5	4,0	4,5	5,0	5,5	6,0	6,5	7,0	7,5	8,0	9,0
k_v-value	16,2	20,4	23,8	26,7	29,5	33,0	37,6	42,3	48,0	54,5	61,5	69,6	80,0	92,9	136

Pre-setting	10,0	11,0	12,0	13,0	14,0	15,0	16,0	17,0 = open
k_v-value	193	240	274	300	320	337	352	k _{vs} = 365